

A25D 25Watt DSP FX **ACOUSTIC AMP**



ARTEC

CONTROL PANEL

TWO WAY FOOT SWITCH
 - tip : CH1 fx on/off
 - ring : CH2 fx on/off

Fx output level
 ** some stereo effects
 output is not
 channel-separated.

Effect select
 1~6 : reverbs
 7~12 : chorus
 or delay

AC POWER INLET

CD / MP3 INPUT
 RCA-JACK

ARTEC Acoustic AZ50 PROFESSIONAL COMPACT ACOUSTIC SYSTEM

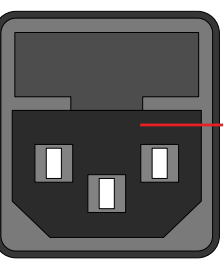
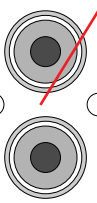

AC210-240V - 50/60Hz 60W
 FUSE: T1A1 250VAC

MIC channel
 BALANCED
 XLR INPUT
 (for MIC or
 ACOUSTIC
 GUITAR)

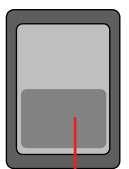
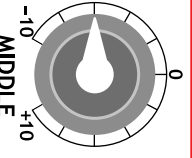
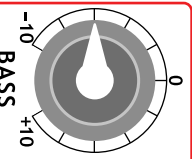
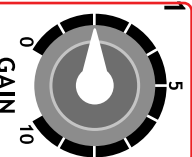
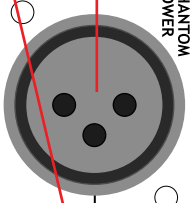

POWER SWITCH
 INDICATOR

CH 1
 Balanced or
 Unbalanced
 Lo-Z INPUT

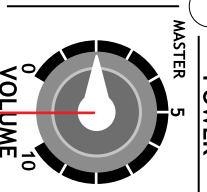
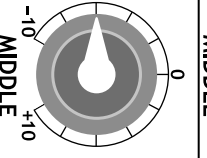
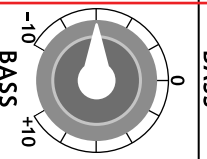
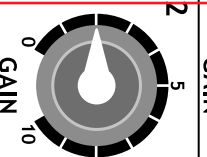
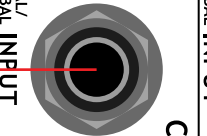
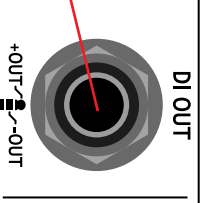

MASTER VOLUME

REC OUT /
 PHONE JACK



CH 2
 Balanced or
 Unbalanced
 Lo-Z INPUT

INPUT GAIN
 CONTROL

3 BAND EQUALIZER

A PRODUCT OF ARTECSOUND CO., LTD. KOREA

MADE IN CHINA



SPECIFICATION

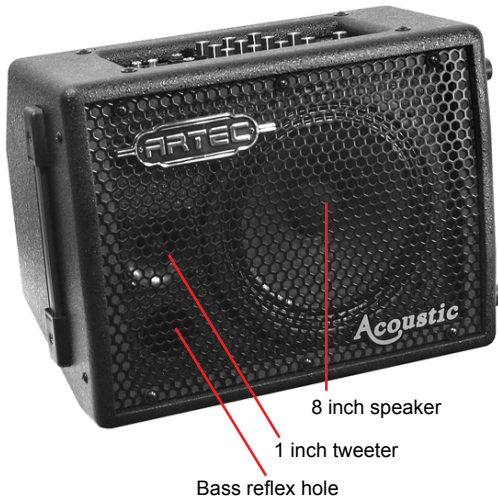

DIMENSION : 275 x 360 x 250 (mm)
SPEAKER : 8 inch LF, 1 inch HF
OUTPUT : 25 watts music power
AC POWER : 60W @ 230V
FREQUENCY RANGE : 80Hz ~ 10kHz

CH 1

LOW-Z BALANCE XLR <Phantom powered>

Max input level : +10dBV, Max gain : 60dB

LOW-Z (10kohm) BAL / UNBAL INPUT

Max input level : +10dBV, Max gain : 60dB

CH 2

LOW-Z (10kohm) BAL / UNBAL INPUT

Max input level : +10dBV, Max gain : 60dB

EQ (Both ch)

Bass frequency : 180Hz peak

Bass gain : -10dB ~ +10dB

Middle frequency : 900Hz

Middle gain : -10dB ~ +10dB

Treble frequency : 2KHz pak

Treble gain : -10dB ~ +10dB

DSP EFFECTS

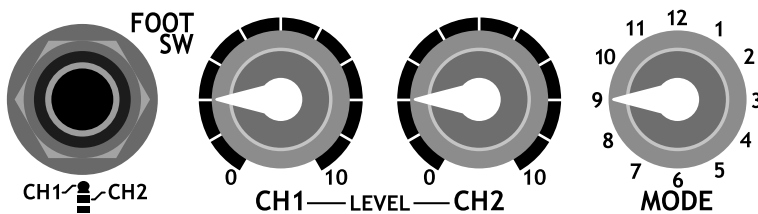

STEREO REVERB MODE		
<ul style="list-style-type: none"> 1 Hall 2 Cathedral 3 Room 1 4 Room 2 5 Room 3 6 Chamber 12 Delay/Reverb 	<p>CH1 INPUT CH2 INPUT STEREO REVERB CH1 OUTPUT CH2 OUTPUT FX LEVEL FOOT SW</p>	<p>CH1 and CH2 LEVEL and FOOT SW will not separate. It have limitation to separate between Ch1 and Ch2. Because stereo effect sound can mix to the other channel.</p>
CHANNEL SEPARATED MODE		
<ul style="list-style-type: none"> 7 Rotary 8 Chorus 1 9 Chorus 2 10 Flanger 11 Vib 	<p>CH1 INPUT CH2 INPUT CH SEPARATED FX CH1 OUTPUT CH2 OUTPUT FX LEVEL FOOT SW</p>	<p>CH1 and CH2 LEVEL and FOOT SW will work as individual effector</p>

BLOCK DIAGRAM

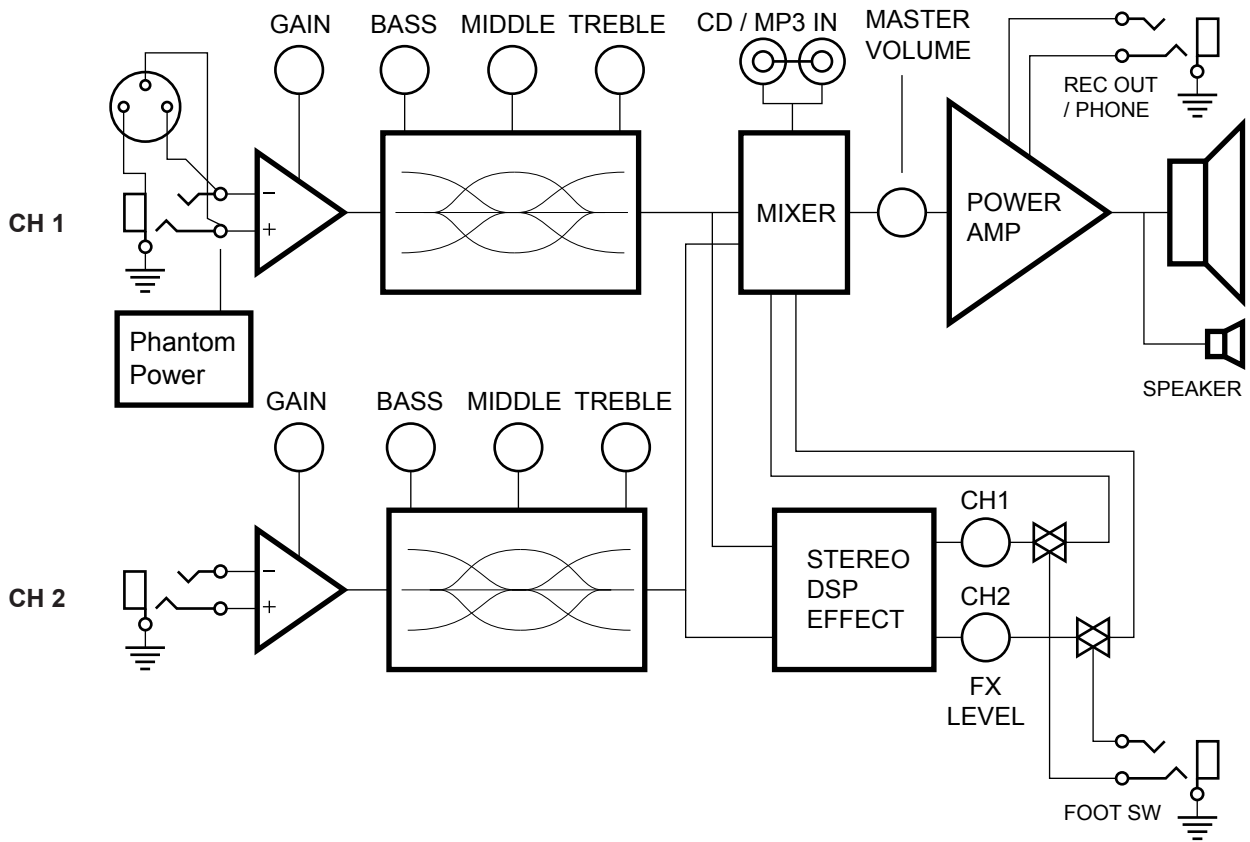

IMPORTANT SAFETY INSTRUCTIONS

- DO NOT OPERATE NEAR ANY HEAT SOURCE AND DO NOT BLOCK ANY VENTILATION OPENINGS ON THIS APPARATUS.
- ONLY CONNECT POWER CORD TO A POLARIZED, SAFETY GROUNDED OUTLET WIRED TO CURRENT ELECTRICAL CODES AND COMPATIBLE WITH VOLTAGE, POWER, AND FREQUENCY REQUIREMENTS STATED ON THE REAR PANEL OF THE APPARATUS.
- ONLY USE ATTACHMENTS, ACCESSORIES, STANDS, OR BRACKETS SPECIFIED BY THE MANUFACTURER FOR SAFE OPERATION AND TO AVOID INJURY.
- WARNING: TO REDUCE THE RISK OF ELECTRIC SHOCK OR FIRE, DO NOT EXPOSE THIS UNIT TO RAIN OR MOISTURE.
- SERVICE MUST BE PERFORMED BY QUALIFIED PERSONNEL.
- OUR AMPLIFIERS ARE CAPABLE OF PRODUCING HIGH SOUND PRESSURE LEVELS. CONTINUED EXPOSURE TO HIGH SOUND PRESSURE LEVELS CAN CAUSE PERMANENT HEARING IMPAIRMENT OR LOSS. USER CAUTION IS ADVISED AND EAR PROTECTION IS RECOMMENDED IF UNIT IS OPERATED AT HIGH VOLUME.